

## Towards an eco-efficient cooling system

### Identifying the most sustainable solution

**When the cooling tower of its Tessengerlo plant reached end-of-life, Panasonic Energy Belgium had two options: replace the cooling tower with the same technology or re-evaluate the entire cooling system in order to achieve greater eco-efficiency. The battery manufacturer chose the latter option and contacted Laborelec for expert guidance.**

Panasonic Energy Belgium was considering a dry cooler instead of a cooling tower. But is a dry cooler the best solution for the Tessengerlo plant? To obtain an objective answer to this question, Panasonic Energy Belgium called upon Laborelec's expertise.

### Screening the entire cooling system pays off

Laborelec investigated various options. 'We evaluated the pros and cons of a dry cooler and even looked into the feasibility of heat recuperation to replace on-site cooling,' explains Thomas Neven. What's more, Laborelec went beyond evaluating alternative technologies. 'We also investigated the site's main energy consumers: the compressors and vacuum pumps. The energy balance revealed that the compressors were responsible for 23% of the Tessengerlo plant's total electricity consumption. Hence, investigating the efficiency of the compressors was certainly merited,' states Neven.

### From identification to improvement

The Laborelec experts formulated various solution scenarios and rated each of them on their total cost of ownership and eco-efficiency. It was apparent that some scenarios would be profitable after only two years. 'We offered Panasonic Energy Belgium concrete advice based on our scenario analyses, thus ensuring the best solution for their specific situation,' concludes Neven.



## At the forefront of energy management

Electrical technology is undergoing important changes. New techniques are emerging rapidly, creating an increasingly interactive environment with new functionalities such as substation automation and local management of electricity consumption and generation. Laborelec is at the forefront of these evolutions. Our experts are investigating promising technologies, as well as developing innovative solutions. Find out more in this edition of Laborelec News.

### Contact

*michael.dekoster@laborelec.com*

### Comparison of the scenarios

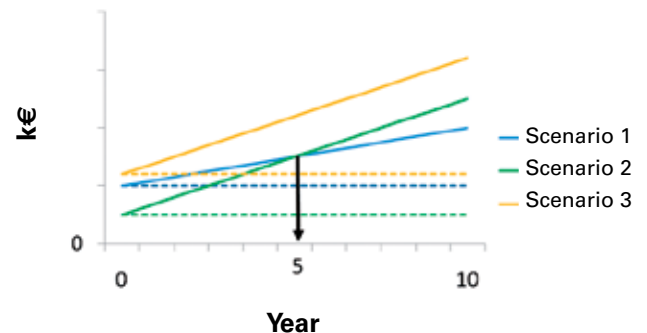

*Different cooling scenarios were formulated and rated on their total cost of ownership and eco-efficiency.*



### In short

- The cooling tower at Panasonic Energy Belgium reached end-of-life
- Laborelec evaluated various cooling technologies, as well as the condition of the main cooling consumers
- Analysis of various solution scenarios on total cost of ownership and eco-efficiency revealed the best solution



For more information, contact  
*bohdan.soroka@laborelec.com.*

# NEWS: focus on electricity grids and end-use

## Flemish project to test energy management systems

Laborelec is taking part in the Local Intelligent Networks and Energy Active Regions (LINEAR) project of the Flemish Region in Belgium. One of the goals of the project is to evaluate customer response in the presence of sub-metering and load management systems in order to reap the benefits of residential load flexibility.

The LINEAR project also plans to test active load management features in the field, at both the household level and neighbourhood level. Part of the testing for the LINEAR project will take place in the Laborelec Smart Lab (see text box). The project is being jointly carried out by thirteen research centres and industrial partners.

### Testing emerging technologies

Numerous energy technologies are emerging in the residential sector. They include everything from photovoltaic panels and heat pumps to intelligent boilers and electric vehicles. Little is known about the way these devices interact within a household. The LINEAR project is one of the first of its kind to jointly test all of these devices together with energy management systems. Laborelec is taking part in the project, among other things by modelling a residential environment containing all of these devices.

### Optimizing load balancing within a household

Another goal of the project is to determine how emerging technologies can be used to optimize residential energy production and consumption. 'The project will enable us to test multiple consumption and production scenarios involving decentralized energy sources and loads. We will investigate how to program emerging devices in order to improve load balancing within a residential environment,' states Cathy Crunelle. 'Using the project, we aim to develop our understanding of how to optimize the operation of each of these devices.'

### Answering stakeholder questions

The LINEAR project will also enable the partners to precisely answer questions from stakeholders regarding new residential technologies. 'An important aspect to evaluate in this respect is flexibility,' states Rafaël Jahn. 'For instance, until what point can consumers shift or shed certain loads without sacrificing comfort?'

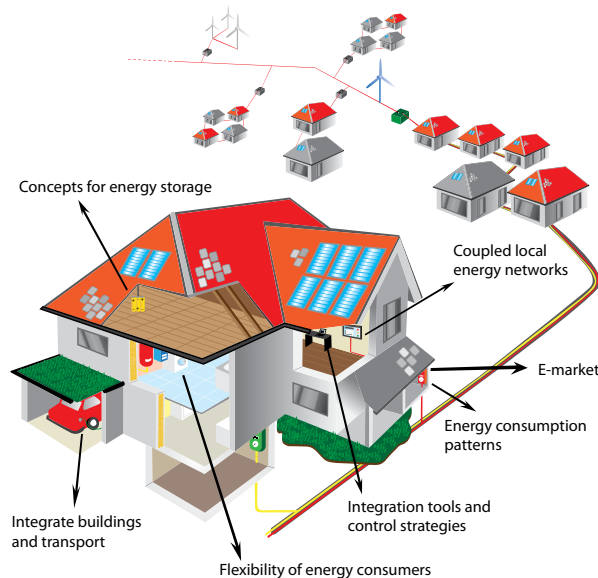

*In the Flemish LINEAR project, Laborelec is investigating how to manage electricity consumption of household devices according to electricity availability.*



### In short

- Laborelec is setting up a test environment to assess the impact of new residential energy technologies on electricity consumption
- The LINEAR project will research how to optimize load balancing at the household level
- Our experts will also test the efficiency, flexibility, and accuracy of energy management systems



### Smart Lab brings together residential energy technologies

The goal of the Smart Lab is to develop knowledge of energy management systems. Our experts will test the performance of sub-metering and load management systems, as well as the reaction to real-time inputs. 'We will carry out an independent technical evaluation, focusing on metrological precision and user-friendliness,' explains Laurent De Vroey. 'A key task will be to verify the feedback that consumers receive from their energy management system.' The Smart Lab is being constructed at Laborelec Belgium over a total surface of 100 m<sup>2</sup>. It will be operational in the fall of 2011.



For more information, contact  
[rafael.jahn@laborelec.com](mailto:rafael.jahn@laborelec.com).

## Improved interfacing between substation automation components

**Grid owners have started adapting their electrical substations in order to comply with the IEC 61850 standard for the design of electrical substation automation. Laborelec helps grid owners assess the impact on substation engineering and the interoperability of substation automation components beyond the standard's requirements.**

### Automation component interoperability

Each substation automation component brand has its own information model and communication protocol, which complicates the interoperability of devices within a substation. The IEC 61850 standard aims to harmonize the information models and communication between substation components. This will enable the unrestricted exchange and use of data in order for each component to perform their dedicated functionality.

### Enhanced substation automation

'This standardization will make grid owners less dependent on a specific manufacturer, since substation components will effectively become more open,' explains Hans Bastings. 'It will also make it easier for grid owners to engineer all functions within a substation. Furthermore, this approach is Ethernet-based, which will considerably reduce wiring needs.'

### From advice to component testing

'The implementation of the standard, however, can be challenging for grid owners because it impacts engineering and substation information modelling and communication,' adds Bastings. Laborelec provides assistance in modelling substations in compliance with this standard. 'We closely follow the IEC 61850 standard and help grid owners improve substation automation accordingly. We also carry out tests on substation devices in order to find out whether they comply with customer needs and whether they correctly interact with other components as declared by the manufacturers.'

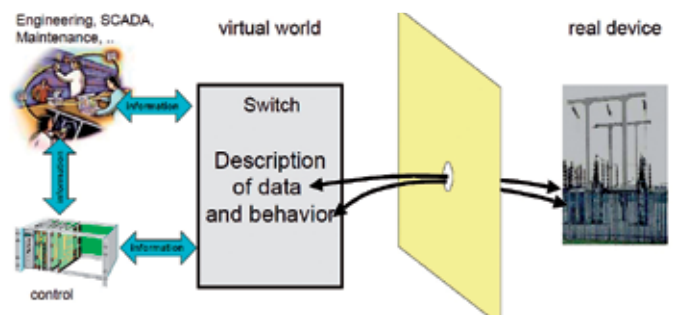

*Laborelec assists grid owners in complying with the IEC 61850 standard for substation automation design.*



**For more information, contact**  
[rafael.jahn@laborelec.com](mailto:rafael.jahn@laborelec.com).



## Monitoring electric vehicle behaviour

As part of a project initiated by Electrabel and Cofely Services, Laborelec has started monitoring electric vehicle performance, behaviour, and wear over time. Our experts are testing five vehicles: one is used as a service vehicle at Laborelec, and the others are used as private cars by four GDF SUEZ employees, among which two work at Laborelec.

The vehicles have been equipped with monitoring systems that register parameters such as battery consumption in function of driver behaviour and the impact of climatic conditions on vehicle performance. Laborelec is planning to carry out these tests over an entire year, starting end of June.



*Several GDF SUEZ employees are using the electric vehicles as part of the testing program.*

## Offshore energy storage: what's its potential?

The Flemish Region in Belgium has launched a research project focused on offshore electricity storage. The concept involves an island or platform that collects and stores electricity generated by offshore wind turbines in order to meet fluctuations in electricity demand more cost-effectively. The Flemish authorities contacted Laborelec to carry out a pre-feasibility study.

### Evaluating available storage technologies

Over the years, Laborelec has acquired considerable expertise in the field of electricity storage. This enables us to assess which technologies offer the greatest electricity storage potential in this specific project. 'We are looking into a wide variety of options, including batteries, electromechanical storage, and compressed air energy storage,' explains Marc Locht. 'For each technology, we are evaluating key parameters such as surface requirements, storage capacity, and load/unload speed.'

### Determining the return on investment

Laborelec is also calculating the return on investment for this storage concept. 'We are analyzing numerous factors, such as the impact on load balancing costs and the minimum storage volumes required to make the system financially attractive,' adds Locht.

## Optimal design and operational excellence of electrical power systems

**Electricity networks are ageing and becoming progressively more complex. In such a context, it is becoming increasingly difficult for public and industrial grid operators to save on maintenance and exploitation costs. Laborelec helps them achieve operational excellence within their electrical networks in cost-effective ways.**

Laborelec has expert know-how in the field of grid technologies. Our experts have worked on projects involving all types of electrical networks, in a wide variety of sectors and environments. 'This background enables us to provide well-founded, accurate advice on both the design and exploitation processes. We believe this combination is paramount for maximum performance at the lowest cost,' explains Sven Kerremans. 'This approach ensures optimal network reliability, a secure electrical environment, maximum equipment lifetime, and minimum total cost of ownership.'

Interested in the brochure? Contact [sven.kerremans@laborelec.com](mailto:sven.kerremans@laborelec.com).

'We are also investigating the potential of connecting several offshore wind turbines to the island or platform in order to limit the number of large cables carrying electricity to the mainland.' The study is still ongoing.

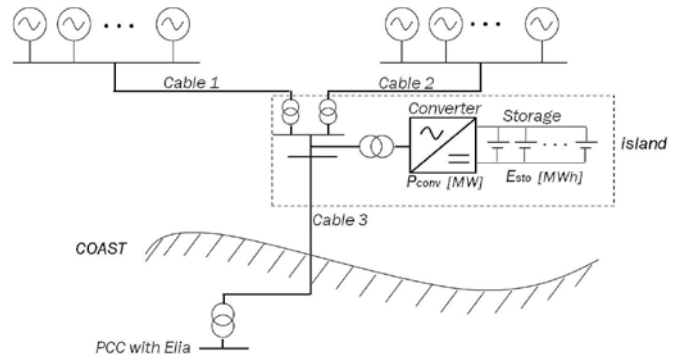

*Laborelec was asked by Flemish authorities to carry out a pre-feasibility study of the potential of offshore electricity storage.*



For more information, contact  
[sven.kerremans@laborelec.com](mailto:sven.kerremans@laborelec.com).



### Supporting companies in the third phase of the Emission Trading System

In the framework of the third phase of the Emission Trading System, industrial companies throughout Europe are finalizing their emission dossiers. Laborelec assisted various companies in Belgium in completing their reports. 'For each site, we investigated the thermal consumption in order to define the net thermal consumption for various production processes. This enabled us to calculate the company's free CO<sub>2</sub> emission allowances,' explains Frederiek Demeyer. Laborelec incorporated these data and other information into a comprehensive report for submission to the benchmark verification bureau. Based on the verification bureau's feedback on the dossier, our experts will give advice on the appropriate actions to take.

For more information, contact  
[bohdan.soroka@laborelec.com](mailto:bohdan.soroka@laborelec.com).